

## WALL MOUNT COMMERCIAL BRUSHED NICKEL AUTOMATIC XT5 SENSOR FAUCET SPECS

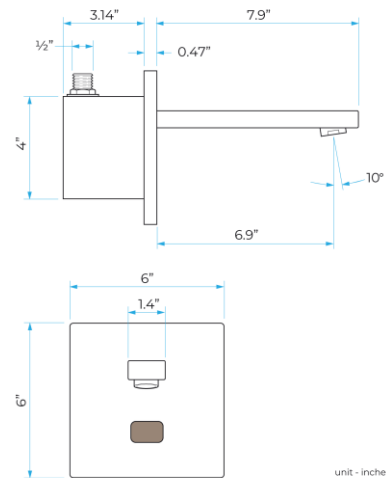

### Specs:

- 220-240V OR 4X 1.5 AA BATTERIES
- Water Consumption: 0.05Mpa-0.6Mpa
- Detection Zone: 450M ≥500MM
- Motor valve lifespan: up to 500000 flushes
- Battery lifespan: 100000 cycles
- Static Power Consumption: 0.36mw
- Working Power consumption: 0.5mw
- Inductive Opening Time: < 1 second
- Inductive Closing Time: < 2 second
- Connection Size 1/2"
- Mixer valve : AQM-WRM-T301-CON-CP
- Test Range 0.2-5 Bar
- Min. Operating Pressure 1.0 BAR MP

